

Special Schools Portfolio

Issue 3





Contents

01. Bath, Toilet & Shower	5
02. Patient Handling	13
03. Ceiling Hoists	28
04. Pressure Care	35
05. Wheelchairs	40
06. Seating	46
07. Mobility Solutions	49
08. Bedroom Solutions	52

Special Schools Portfolio

For over 30 years, Active Medical Supplies has delivered safe and innovative solutions for the care of clients in the Aged Care, Hospital, School and Home Care sectors. We strive to provide the highest quality equipment for Special Schools that provides a safe environment and will withstand the test of time.

We partner with experts in the field of design and manufacturing to provide the very best resources to ensure that your loved ones are provided with the correct equipment to receive optimum care.

We have a commitment to lower our carbon footprint and protect our environment. We utilise our own delivery vehicles and use sustainable materials for packaging to reduce environmental damage. We are also proud to provide beds and equipment with world leading, energy-saving electronics.

For your peace of mind our product is manufactured to very high quality and we have a secure supply chain. 90% of our products are sourced from Australia, Europe, USA, Canada, United Kingdom, Spain, India, Sweden, Vietnam and Taiwan.

We help Health Care Providers to Provide Better Patient Outcomes

Our Home Care team work hard to meet the needs of not only the patients who require assistive products, but also the carers who support them. We aim to provide our community with the best equipment to make life easier. For more information on NDIS and what we have to offer visit our website at www.activemedicalsupplies.com.au

NDIS Organisation ID# 4050014772



01.

Bath, Toilet & Shower

Juvo Height Adjustable Shower Commode with Swingaway Footplates	6	Juvo Commode Pan Rack	9
Juvo Attendant Propelled Shower Commode with Sliding Platform	6	Wall Mounted Change Table	10
Juvo Attendant Propelled Shower Commode with Swingaway Legrests	7	Change Table - Electric	10
Juvo Paediatric Shower Commode	7	Change Table - Electric	11
Juvo 'Tilting in Space' Shower Commode	8	Change Table - Electric	11
Bed Pan	9	Staebel Shower Trolley	12
		Staebel Junior Shower Trolley	12



Juvo Height Adjustable Shower Commode with Swingaway Footplates

- Attendant propelled
- Height adjustable up to 90mm front and rear axle.
- Assists transportation of the patient for showering and toileting
- Can be positioned over the toilet
- Durable total stainless steel frame
- Selection of seamless PU padded seats & pressure care seats (open or closed front)
- Removable seat
- Reinforced seat/back frame
- Swing away, removable and height adjustable legrests with flip up footplates
- Patented design, no protrusions
- Stainless steel 125mm castors (4 braking)
- Swing back independent armrests to assist in side transfer and patient access
- Safety arms provide user security and safety
- Stainless steel pan rack guides
- This product is tested and certified to Australian Standards
- Seat sold separately (NB Pictured with hand padded closed front option)
- Other sizes available



Specifications:

Product Code	1913J
Seat Width	460 mm
Anterior Seat Height	590 mm
Posterior Seat Height	565 mm
Width Between Arms	540 mm
Overall Width	540 mm
SWL	200 kg



Juvo Attendant Propelled Shower Commode with Sliding Platform

The ultimate in strength, quality and stability this Juvo mobile shower chair is ideal for the Petite client! The wheelbase design prevents forward tipping and has proven to be an effective solution in all areas from home to aged care to hospital.

- Attendant propelled
- Quality stainless steel frame for longevity in a demanding environment
- Flip up armrests for ease of side transfers
- Armrests can be flipped so that they are positioned in front of occupant to reduce risk of slipping forward when being wheeled
- Smooth, slatted backrest design to facilitate easy cleaning
- Generous size sliding stainless steel footplate, weight bearing to utilise as a commode you must source the slide-in pan rack
- Other sizes available



Specifications:

Product Code	1904J
Seat Width	410 mm
Width Between Arms	440 mm
Overall Height	1020 mm
Backrest Height	340 mm
Seat to Heel	400 mm
Anterior Seat Height	595 mm
Toilet Clearance - Width	360 mm
Toilet Clearance - To Pan	315 mm
Toilet Clearance - Under Pan	480 mm
SWL	200 kg



Juvo Attendant Propelled Shower Commode with Swingaway Legrests

This genuine paediatric / small adult chair reflects quality and design.

- Attendant propelled
- Stainless steel frame for longevity
- Flip up armrests for ease of side transfers
- Slatted backrest design which facilitates easy cleaning
- Safety armrests can be flipped so that they are positioned in front of occupant to reduce risk of slipping forward when being wheeled
- Swingaway adjustable footplates with unique design that reduces skin tear risk
- Four stainless steel braking castors
- Tested and certified to Australian Standards
- Other sizes available



Specifications:

Product Code	1905J
Seat Width	410 mm
Anterior Seat Height	590 mm
Posterior Seat Height	565 mm
Overall Width	500 mm
SWL	200 kg



Juvo Paediatric Shower Commode

- Adjustable Backrest design - Adjust the backrest angle from 90 to 120 degrees to improve client comfort and access for the carer.
- Depth adjustable seat - Adjust the seat depth to suit smaller client by up to 75mm.
- Height Adjustable seat up to 90mm
- Self-propelled option available - frame to accept self-propelling kit



Specifications:

Product Code	1903J
Seat (WxD)	360 x 275 - 340 mm
Width Between Arms	390 mm
Overall (H x W x H)	1020 x 440 x 850 mm
Backrest Height	340 mm
Armrest Height	200 mm
Seat to Heel	200 - 340 mm
Anterior Seat Height	595 mm
Anterior Seat Height Modified	505 mm
Posterior Seat Height	565 mm
Posterior Seat Height Modified	475 mm
Toilet Bowl Clearance (H x W)	500 x 410 mm
Wall to Rear of Aperture	325 mm
SWL	175 kg



Juvo 'Tilting in Space' Shower Commode

- Assists transportation of the patient for showering and toileting
- Gas strut tilt mechanism for smooth and easy tilting
- Multi-position 35° tilt
- Can be positioned over the toilet
- Durable total stainless steel frame
- Selection of seamless PU padded seats & pressure care seats (open or closed front)
- Removable seat
- Reinforced seat/back frame
- Patented TEARSAFE design, no protrusions
- Swing away, removable and height adjustable legrests with flip up footplates
- Patented TEARSAFE design, no protrusions
- Stainless steel 125mm castors (4 braking)

- Swing back independent armrests to assist in side transfer and patient access
- Adjustable seat height
- Two position height adjustable armrests
- Safety arms provide user security and safety
- Stainless steel pan rack guides
- Please note that the seat for this product is sold separately

Electric kit available for all sizes

Seat colours can be varied:



Lemon Twist Lime Lipstick Regal Emerald



Specifications:

Product Code	1951J
Seat Width	460 mm
Overall Width	560 mm
Armrest Height - High	240 mm
Armrest Height - Low	200 mm
Backrest Height from Seat	800 mm
Width Between Arms	490 mm
SWL	200 kg

Sizes Available:

1950J	1952J	1956J	1961J
410 mm	510 mm	560 mm	610 mm
560 mm	610 mm	660 mm	730 mm
240 mm	240 mm	240 mm	240 mm
200 mm	200 mm	200 mm	200 mm
800 mm	800 mm	800 mm	800 mm
440 mm	540 mm	590 mm	610 mm
200 kg	300 kg	300 kg	300 kg

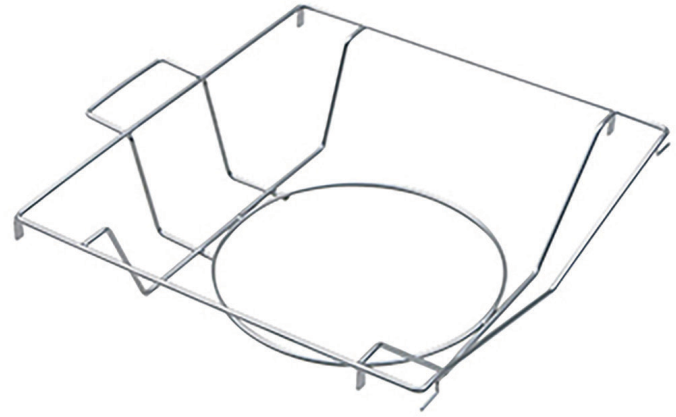
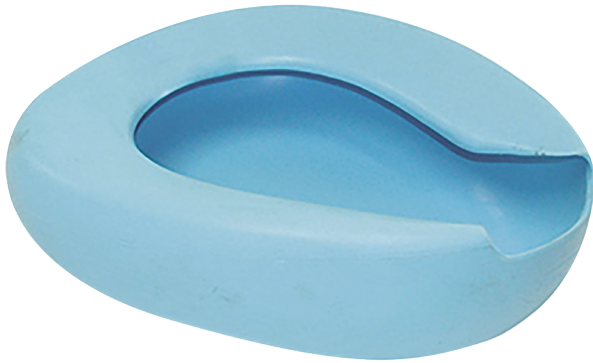

Bed Pan

- These bedpans are made from polypropylene.
- The standard bedpan is heavy duty and ideal for institutional use.
- Bedpan is autoclave.
- Frontal opening
- Wide seating area
- Autoclavable for sanitising
- Moulded plastic

Juvo Commode Pan Rack

This pan rack is used in conjunction with a Juvo, sliding under the seat from the rear of the chair to enable commode use. The stainless steel rack can be used with a bedpan or a round bowl. Its unique non tilt sliding action enables safe handling.

- Pan rack guides are standard on all chairs.
- (Please note - bed pan is not included with rack)

Specifications:

Product Code	1990
Width	295 mm
Length	360 mm
Height	115 mm

Specifications:

Product Code	19607
---------------------	-------



Wall Mounted Change Table

- Electric Hi Low
- Padded Top
- Battery Backup
- Anti-Bacterial Powder Coating
- Infa Red Handset (Cordless)
- Safety Side Rails
- Fasteners for Fixing to Wall



Specifications:

Product Code	7808
Electric Hi-Lo	350 - 950 mm
Sleeping Surface Width	700 mm
Sleeping Surface Length	1400 mm
SWL	170 kg

Also Available:

Product Code	7809
Electric Hi-Lo	350 - 950 mm
Sleeping Surface Length	1200 mm
SWL	170 kg



Change Table - Electric

This mobile change table has electric hi-low function for ease of carers. The vinyl padded top is easy to clean and the base has been designed for easy hoist access. Fold down side rails are an optional extra.

- Designed for hoist access
- Handset operated
- Quality Australian made product

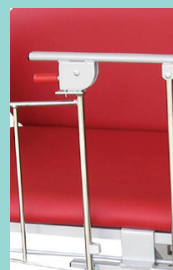

Change Table with Side Rails

An option for the change table range, are the side rails, for extra security where required. They are sold as a pair, and angle downwards to enable transfer off and on the table. • Easy trigger grip release • Vertical bars for safety

Product Code 7801

Specifications:

Product Code	7800
Table Length	1880 mm
Table Width	700 mm
Electric Hi-Lo	620 - 980 mm
Castors	125 mm
SWL	180 kg



Change Table - Electric

The electric heavy duty change table has been designed for stability for heavier patients, and the look is centered on well- designed compact simplicity. It is manufactured with an electric height adjustment with twin towers, which are straight forward to operate, enhancing ease for care activities with its range of heights.

- Handset operated
- Quality Australian made product



Change Table - Electric

Ideal for children, this compact change table features electric hi-lo, padded top, foot control operation. Optional extras include vertical side rails, lap strap.

- 125mm braking castors
- Designed for hoist access
- Foot control operation
- Quality Australian made product



Change Table with Side Rails

An option for the change table range, are the side rails, for extra security where required. They are sold as a pair, and angle downwards to enable transfer off and on the table. • Easy trigger grip release • Vertical bars for safety

Product Code 7801

Specifications:

Product Code	7820
Table Length	1880 mm
Table Width	700 mm
Electric Hi-Lo	560 - 960 mm
Castors	125 mm
SWL	250 kg



Change Table with Side Rails

An option for the change table range, are the side rails, for extra security where required. They are sold as a pair, and angle downwards to enable transfer off and on the table. • Easy trigger grip release • Vertical bars for safety

Product Code 7801

Specifications:

Product Code	7830
Table Length	1400 mm
Table Width	700 mm
Electric Hi-Lo	630 - 930 mm
Castors	125 mm
SWL	90 kg



Staebel Shower Trolley

- Shower trolley with one-section top
- Maximum dimensions: 2070 mm (length) and 810 mm (width)
- Central braking system
- Easy steering system (for ease of maneuvering trolley's front left castor can be locked in direction of steering)
- Side rails – foldable, height: 185 mm with safety release mechanism (Material – powder coated stainless steel)
- Metal base cover
- Water-resistant shower mattress (height: 270 mm)
- Mattress integrated drain with 645 – 2000 mm long flexible hose
- Water-resistant head pillow – semi-cylinder
- Trolley weight: 103 kg

Staebel Junior Shower Trolley

- Shower trolley with one-section trolley top
- Trolley top length: 150 cm, trolley top width: 60 cm
- Maximum dimensions: 167 cm (length) and 76 cm (width)
- Adjustable 5° trolley top inclination
- Hydraulic lowering/raising of trolley top via a console from 54 cm to 97 cm
- Castors with diameter of 150 mm
- Central braking system
- Easy steering system (for ease of maneuvering trolley's front left castor can be locked in direction of steering)
- Side rails – foldable, height: 18,5 cm with safety release mechanism" (Material – powder coated stainless steel)
- Metal base cover
- Water-resistant shower mattress (height: 27 cm)
- Mattress integrated drain from 645 – 2000 mm long flexible hose
- Water-resistant head pillow – semi-cylinder
- Trolley weight: 79 kg



Specifications:

Product Code	1209ST
Shower Trolley Top Width	650 mm
Shower Trolley Top Length	1900 mm
Shower Trolley Top Height	540 - 970 mm
Height with Castors	600 - 1030 mm
Trolley Top Inclination	0° - 5°
Length	2070 mm
Width	810 mm
SWL	170 kg



Specifications:

Product Code	1214ST
Shower Trolley Top Width	600 mm
Shower Trolley Top Length	1500 mm
Shower Trolley Top Height	540 - 970 mm
Height with Castors	600 - 1030 mm
Trolley Top Inclination	0° - 5°
Length	1670 mm
Width	760 mm
SWL	170 kg

02.

Patient Handling

Neos Patient Hoist	14	Pivot Frame Sling	21
Sonata Patient Hoist	15	Pivot Frame Sling	21
Alto 200 Patient Hoist	16	General Purpose Sling	22
Salsa 200 Standing Lifter	17	General Purpose Sling with Head Support	22
Standard Yoke	18	Pivot Balance Head Support Sling	23
Pivot Attachment with Integrated Weigh Scales	18	Pivot Elevate Head Support Sling	23
Pivot Frame	18	Allegro Salsa Sling	24
Four Point Yoke	18	Staebel Patient Transfer	24
Standard Yoke with Weigh Scales	19	Return Transfer Platform	25
Lifting Frame with Gliders	19	Return Belt	25
Pivot Frame - Self Powered	19	Camel Emergency Lifting Device	26
Tri Hook Yoke	19	Elk - Emergency Lifting Device	26
Universal Deluxe Sling with Head Support	20	Staebel Transfer Platform	27
General Purpose Sling with Head Support	20	Staebel Belt	27



Featuring Linak Jumbo Care advanced diagnostic control system.



Neos Patient Hoist

A new generation light weight aluminium lifter evolved from the needs of the carer.

- Aluminium lift with a Safe Working Load (SWL) of 150kg
- Folding design for convenient storage and transfer
- Linak powered lifting function
- Foot pedal control base with adjustment

- Strong and comfortable handles for easy manoeuvring
- Equipped with 75mm front castors and 100mm lockable rear castors
- Jumbo Care diagnostic control and service monitor system
- Easy access emergency stop button
- Electric and manual emergency lowering devices
- Anti-entrapment feature – lowering of boom stops on resistance.



Specifications:	
Product Code	2878
Min Yoke Height	410 mm
Max Yoke Height	1650 mm
Overall Height (Max)	1850 mm
Overall Width	620 mm
Overall Depth	1290 mm
Overall Height (Folded)	1230 mm
Overall Depth (Folded)	460 mm
Turning Radius	135°
SWL	150 kg



Standard Yoke

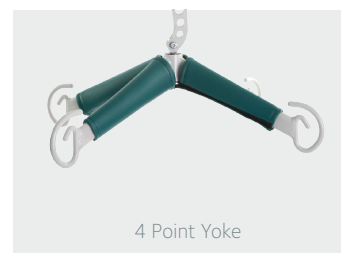

4 Point Yoke

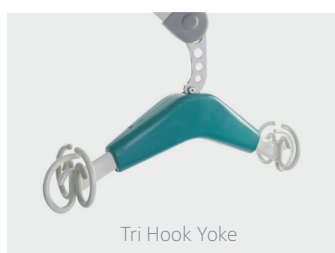

Tri Hook Yoke

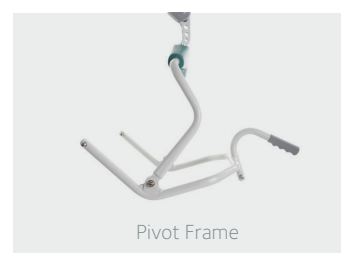

Pivot Frame



Powered Pivot Frame

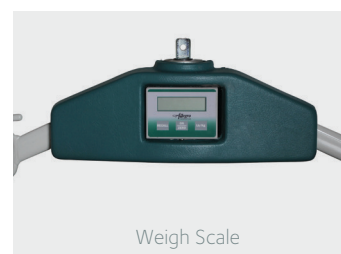

Weigh Scale

Sonata Patient Hoist

A lightweight, compact mobile patient lifting hoist with innovative and ergonomic design the Sonata 150 is an easy to use everyday lifter. With a safe working load of 150 kg the Sonata offers an outstanding lift capacity in a small patient lifter. It utilises the SPACELINK™ concept, a breakthrough for optimised patient space, that enhances floor lift capability and increases maximum lifting height.

With maintenance free bushes in all the major moving parts this hoist is an Australian Made example of quality and strength that is hard to find in other patient lifters.

The Allegro range of patient lifting equipment including lifters and accessories has been designed and tested to comply with: AS ISO 10535-2002 Hoists for the transfer of disabled persons – Requirements and test methods.

- Manual leg adjustment is a standard feature.
- Supplied complete with battery, in-built battery charger and instruction manual.



Specifications:

Product Code	2880
Base Length	1005 mm
External Base Width Closed	605 mm
External Base Width Open	1070 mm
Internal Base Width Closed	510 mm
Internal Base Width Open	975 mm
Base Width Adjustment	3 Position Manual
Under Bed Clearance	130 mm
Minimum Height of Yoke	420 mm
Maximum Height of Yoke	1735 mm

Hoisting Range*	870 mm
Minimum Storage Height	1260 mm
Under Base Height	55 mm
Maximum Hoist Reach	875 mm
Minimum Hoist Reach	555 mm
Hoist Reach at Maximum Height	555 mm
Mass of Heaviest Part (Mast Assembly)	22 kg
Lifter Weight	41 kg
SWL	150 kg

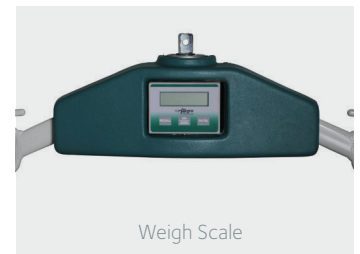
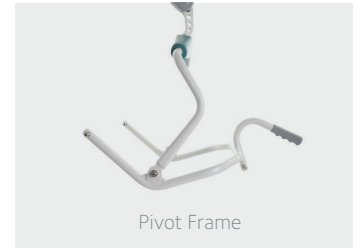
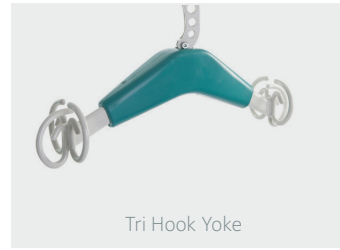

Alto 200 Patient Hoist

Alto Lift 200: A medium sized heavy duty mobile patient lifting hoist with a safe working load of 200kg and a compact ergonomic design. The Alto Lift 200, whilst being compact, provides superior patient lift space through the use of SPACE LINK™ technology.

The Alto Lift 200 is the lifter of choice for institutional use or home care where a high capacity lift is required. Designed and tested to comply with: AS ISO 10535-2002 Hoists for transfer of disabled persons - Requirements and test methods.



Specifications:

Product Code	2891 + 2882	Hoisting Range*	1620 mm
Base Length	1150 mm	Minimum Storage Height	1350 mm
External Base Width	645 mm	Under Base Height	50 mm
Maximum Internal Length	860 mm	Maximum Hoist Reach	1060 mm
Internal Base Width Closed	578 mm	Minimum Hoist Reach	610 mm
Internal Base Width Open	1130 mm	Max Hoist Reach at Max Height	4400 mm
Base Width Adjustment	Electric	Min Hoist Reach at Min Height	430 mm
Under Bed Clearance	125 mm	Handle Height	1000 mm
Minimum Height of	420 mm	Turning Radius	1210 mm
Spreader Bar	300 mm	Mass of Heaviest Part (Base Assembly)	17.5 kg
Maximum Height of	870 mm	Lifter Weight	42 kg
Spreader Bar	1920 mm	SWL	200 kg



Salsa 200 Standing Lifter

Designed as an active standing aid allowing a single carer to raise a patient into a comfortable secure standing position. The Salsa 200 is ideal for transferring from bed to chair, or chair to commode. Allegro Concepts standing slings are manufactured to suit the Salsa, allowing superior access for dressing and personal hygiene.

With a small footprint and low overall weight, the Salsa 200 is highly maneuverable. A high capacity safe working load of 200kg means the Salsa is equally at home in an institutional or home environment.

Designed and tested to comply with: AS ISO 10535-2002 Hoists for the transfer of disabled persons – Requirements and test methods.



Specifications:

Product Code	27700	Minimum Height Lift Arm	880 mm
Base Length	1010 mm	Maximum Height Lift Arm	1685 mm
External Base Width Closed	665 mm	Under Base Height	55 mm
External Base Width Open	1030 mm	Lifter Weight	51 kg
Internal Base Width Closed	565 mm	Minimum Storage Height	1190 mm
Internal Base Width Open	930 mm	Footplate	Removable
Base Width Adjustment	Electric	Kneepad	Height Adjustable
Under Bed Clearance	130 mm	SWL	200 kg



Standard Yoke

For Alto MKII 2000 Passive Hoist.

- Sold as each
- Secure press fit plastic protectors to minimise leg damage
- Easy clean option



Pivot Attachment with Integrated Weigh Scales

Complete as one attachment, this allows for standard lifting without losing any critical lift height with separate attachment. Weighing scale Safe Weight Limit 300kg.

- Suitable for allegro Sonata & Alto Hoists.

Specifications:

Product Code 2882

Specifications:

Product Code 2895



Pivot Frame

The pivot frame is used with the pivot sling. The frame spreads the sling attachment points to ensure the patients hips are not flexed excessively, avoiding discomfort some patients experience with standard slings. The ability to position a person in a sitting or lying position, assisting in providing correct seating and positioning.



Four Point Yoke

- Salsa Handle Kit to aid in increased patient security whilst lift is in motion
- Suitable for the Salsa Standing Lifter
- Optional Extra

Specifications:

Product Code 2884

Specifications:

Product Code 2886



Standard Yoke with Integrated Weigh Scales

Complete as one attachment, this allows for standard lifting without losing any critical lift height with separate attachment. Weighing scale Safe Weight Limit 300kg. Suitable for allegro Sonata & Alto Hoists.



Lifting Frame with Gliders

The Lifting Frame is an essential piece of equipment for the safe lifting and handling of patients requiring spinal or orthopaedic immobility.

The specialised frame made from a durable metal comes complete with 12 removable nylon gliders and can be dismantled for ease of storage. Strap kit sold separately. *Pictured being utilised with 4-point yoke. SWL 200kg.

Specifications:

Product Code

2894

Specifications:

Product Code

227201



Pivot Frame - Self Powered

Self-powered patient positioning, no power required from hoist Universal application, easily adaptable to any style of patient hoist Controlled via button on Pivot Frame handle

Removable battery for charging



Tri Hook Yoke

These three heavy duty hoists are available with a choice of 6 different sling attachment options. Achieve quality patient transfers by selecting the fitting which best suits your client or healthcare facility.

Can be used with general purpose (loop attachment) slings

Specifications:

Product Code

2884-1

Specifications:

Product Code

2883

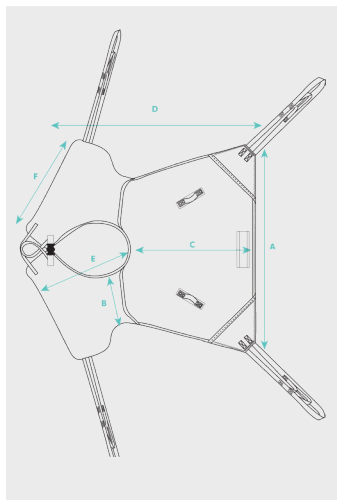
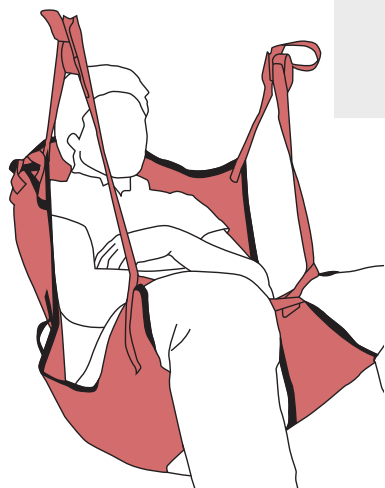

Universal Deluxe Sling with Head Support

This sling is good for all standard transfers and is exceptionally comfortable for the patient. The leg sections are shaped to provide good support to the hip and thigh areas. It is designed to hold the leg more securely than standard sling leg sections, as the leg is held from both sides instead of just the inside of the leg. The leg sections also spread the load over a larger area on the patient's legs so tend to reduce the pressure on the underside of the legs.

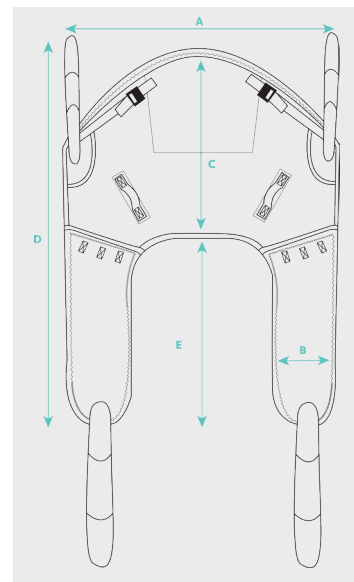
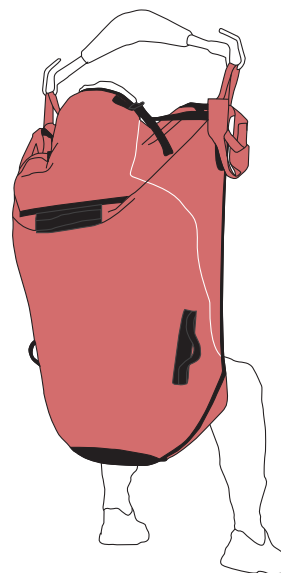

General Purpose Sling with Head Support

The General Purpose Head Support sling, as the name suggests, is a full body support style sling and is recommended for general lifting and in situations of lifting from the floor, and for the less secure patient. The loop style attachments have three lengths at each connection point and are used on a patient lifter with a yoke style attachment. Available in sizes from x-small through to XX-large and in mesh or fabric options, this is a popular choice for individuals and care facilities alike.

ActiveCare Mesh		ActiveCare Fabric		ActiveCare Parasilk	
XS	227430	XS	227435	XS	227440
S	227431	S	227436	S	227441
M	227432	M	227437	M	227442
L	227433	L	227438	L	227443
XL	227434	XL	227439	XL	227444
	XS	S	M	L	XL
A	715	800	900	1000	1105
B	160	185	210	235	260
C	685	815	945	1075	1205
D	1000	1175	1355	1535	1710
E	295	340	385	430	475
F	375	440	500	560	625

ActiveCare Mesh		ActiveCare Fabric		ActiveCare Parasilk	
XS	227210	XS	227209	XS	227410
S	227126	S	227247	S	227411
M	227127	M	227067	M	227412
L	227128	L	227069	L	227413
XL	227248	XL	227205	L	227413
XXL	227212	XXL	227211	XL	227414
	XS	S	M	L	XL
A	795	895	995	1120	1240
B	190	210	230	245	250
C	685	790	895	995	1080
D	1085	1270	1440	1595	1735
E	585	650	700	740	780

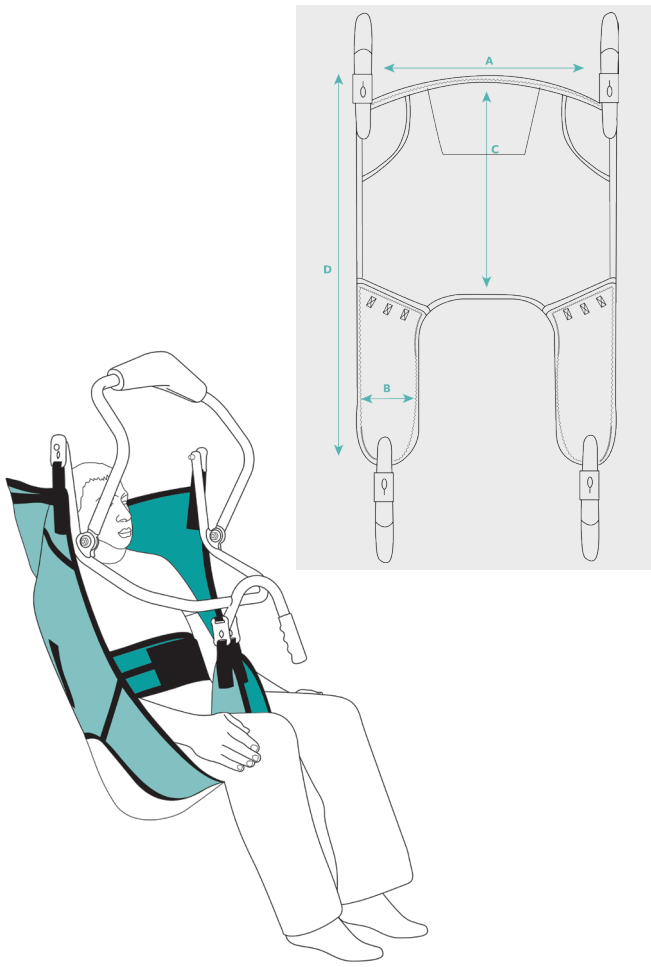
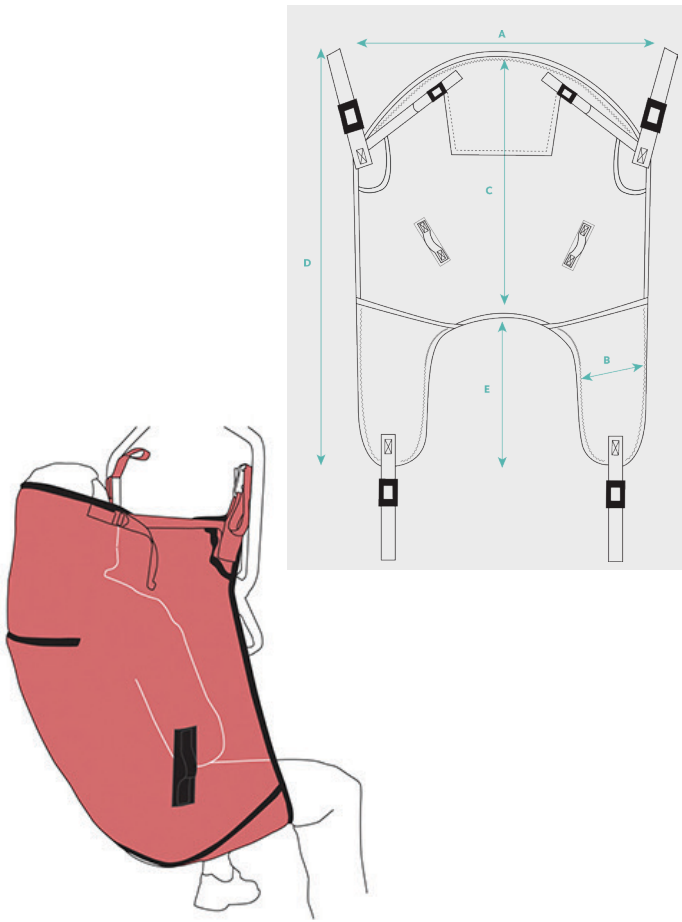

Pivot Frame Sling

The Pivot sling is designed for use with the pivot/tilt frame. It attaches with the keyhole tags engineered to the highest standards in strength and size tolerances and feature auto clip on action (no safety straps required). It also features sling centre marking and positioning handles to assist correct positioning and woven label that will not wash out or fade.

Available in sizes from x-small through to XX-large and in fabric or mesh styles.

Pivot Frame Sling

The Pivot sling is designed for use with the pivot/tilt frame. It attaches with the keyhole tags engineered to the highest standards in strength and size tolerances and feature auto clip on action (no safety straps required). It also features sling centre marking and positioning handles to assist correct positioning and woven label that will not wash out or fade.

Available in sizes from x-small through to XX-large and in fabric or mesh styles.

ActiveCare Mesh		ActiveCare Fabric		ActiveCare Parasilk			
XXS	227239	XXS	227131				
XS	227240	XS	227130	XS	227420		
S	227241	S	227133	S	227422		
M	227242	M	227134	M	227423		
L	227243	L	227135	L	227424		
XL	227244	XL	227136	XL	227425		
XXL	227238	XXL	227132	XXL	227426		
XXS	XS	S	M	L	XL	XXL	
A	697	797	897	997	1120	1240	1360
B	170	190	210	230	245	250	250
C	250	685	790	895	995	1080	1125
D	875	1060	1230	1385	1525	1650	1725
E	295	375	440	490	530	570	600

Allegro Mesh		Allegro Mesh				
XS	27P02XS	XS	27P01XS			
S	27P02S	S	27P01S			
M	27P02M	M	27P01M			
L	27P02L	L	27P01L			
XL	27P02XL	XL	27P01XL			
XXL	27P02XXL	XXL	27P01XXL			
XS	S	M	L	XL	XXL	
A	720	870	1000	1000	1170	1320
B	190	230	270	260	270	290
C	580	830	920	1010	1090	1180
D	870	1220	1310	1410	1540	1710

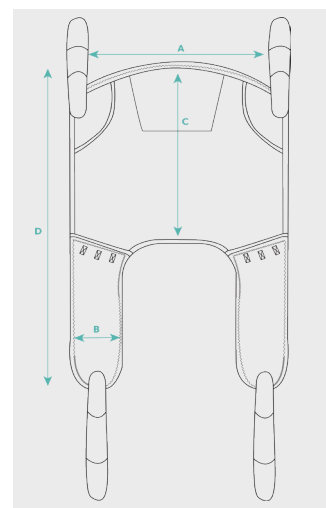
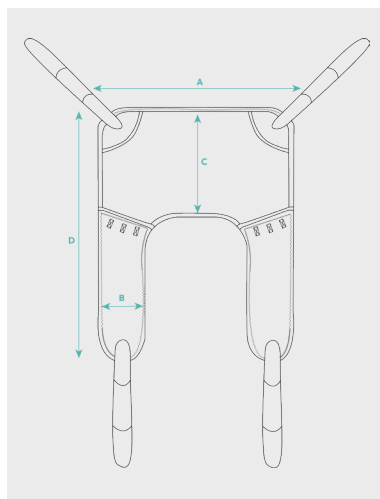
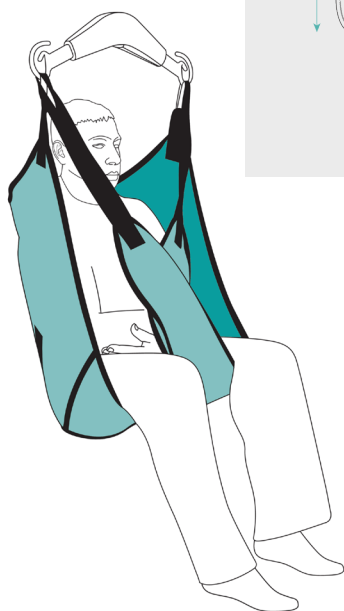

General Purpose Sling

The General Purpose sling is a standard sling providing good support for those with some upper body control. Suitable for general lifting for patient lifters with a yoke style attachment, and available in sizes from X-small to XX-large. Also with the option of fabric or mesh construction, this is a versatile sling that is simple and safe to use.

Also available:

Allegro General Purpose Hygiene Slings With Head Support

General Purpose Sling with Head Support

The General Purpose Head Support sling, as the name suggests, is a full body support style sling and is recommended for general lifting and in situations of lifting from the floor, and for the less secure patient. The loop style attachments have three lengths at each connection point and are used on a patient lifter with a yoke style attachment. Available in sizes from x-small through to XX-large, providing a popular choice for individuals and care facilities. Slings are manufactured from polyester fabric or mesh (suitable for bathing).

Also available:

Activecare General Purpose Hygiene Slings With Head Support

Allegro Mesh		Allegro Fabric		Allegro Mesh		Allegro Fabric	
XS	27GP02XS	XS	27GP01XS	XS	27GPHS02XS	XS	27GPHS01XS
S	27GP02S	S	27GP01S	S	27GPHS02S	S	27GPHS01S
M	27GP02M	M	27GP01M	M	27GPHS02M	M	27GPHS01M
L	27GP02L	L	27GP01L	L	27GPHS02L	L	27GPHS01L
XL	27GP02XL	XL	27GP01XL	XL	27GPHS02XL	XL	27GPHS01XL
XXL	27GP02XXL	XXL	27GP01XXL	XXL	27GPHS02XXL	XXL	27GPHS01XXL
	XS	S	M	L	XL	XXL	
A	790	790	890	1110	1240	1400	
B	210	230	240	260	270	290	
C	470	460	530	650	730	750	
D	1120	1130	1190	1390	1520	1590	
	XS	S	M	L	XL	XXL	
A	820	790	920	1110	1270	1360	
B	210	230	240	260	270	290	
C	750	780	920	1000	1020	1050	
D	1310	1280	1410	1630	1680	1780	

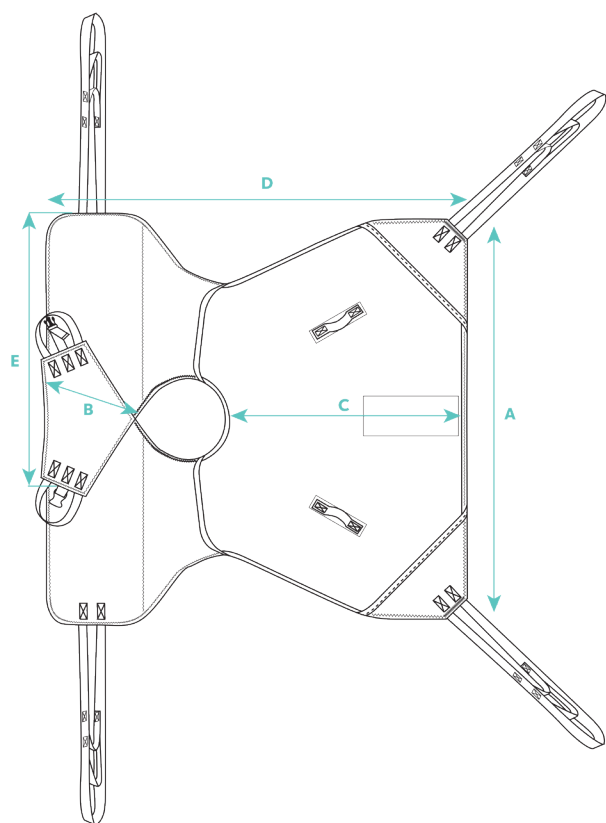

Pivot Balance Head Support Sling

The Pivot Balance Head Support Sling is a sling for general lifting and transfers with a standard 'cupped-leg' design and a head support section. This style provides excellent support to the legs and a very comfortable lift. Suitable for amputees, patients with low muscle control requiring full support and in situations where the user stays in the sling for long periods.

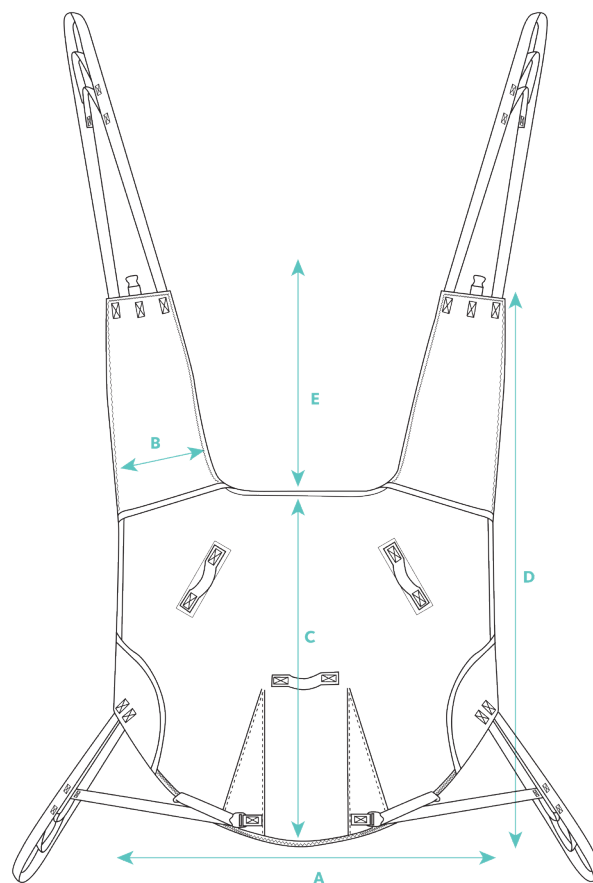

Pivot Elevate Head Support Sling

The Pivot Elevate Head Support Sling is a sling with head support made for general lifting and transfers with a standard 'open-leg' design. It can be easily fitted either in bed or in a chair. Suitable for people who have low muscle control and require full support.

ActiveCare Fabric

XS	227460
S	227461
M	227462
L	227463
XL	227464

	XXS	XS	S	M	L	XL	XXL	XXL
A	640	740	840	940	1060	1180	1300	1420
B	155	185	215	250	280	315	350	380
C	580	695	810	925	1070	1150	1195	1195
D	930	995	1160	1325	1520	1655	1750	1800
E	475	535	590	650	705	760	815	875

ActiveCare Fabric

XS	227470
S	227471
M	227472
L	227473
XL	227474

	XXS	XS	S	M	L	XL	XXL	XXL
A	705	805	905	1005	1125	1245	1355	1485
B	170	190	210	230	250	255	260	260
C	580	695	810	925	1065	1150	1195	1195
D	940	1115	1280	1430	1600	1715	1780	1805
E	360	420	470	505	535	565	585	610

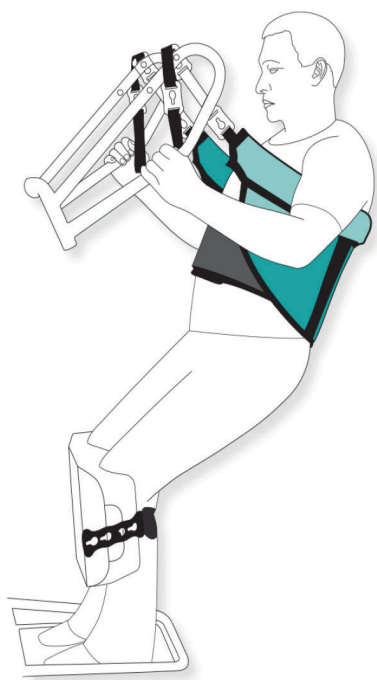

Allegro Salsa Sling

The Salsa sling is for use with the Salsa stand up hoist. It features optimum back support and under arm padding for a safe and comfortable lift and also allows for the easy removal of clothing for toilet transfers.

The Allegro Salsa sling features a torso band for security and stability with buckle (b) or Velcro v(v) fastening

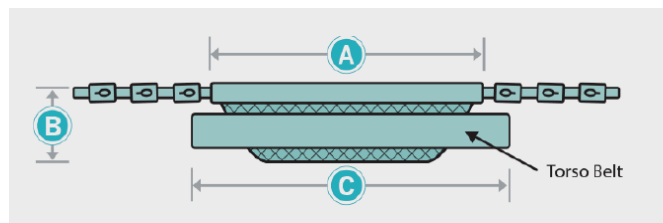

Specifications:

Buckle Fastening

Product Code	27701	27702	27703	27704
Size	Small	Medium	Large	Extra Large
A	880 mm	880 mm	1060 mm	1220 mm
B	290 mm	290 mm	370 mm	410 mm
C (b)	960 mm	960 mm	1020 mm	1220 mm
C (v)	1180 mm	1180 mm	1320 mm	1440 mm

Velcro Fastening

Product Code	27705	27706	27707
Size	Medium	Large	Extra Large
A	880 mm	1060 mm	1220 mm
B	290 mm	370 mm	410 mm
C (b)	960 mm	1020 mm	1220 mm
C (v)	1180 mm	1320 mm	1440 mm



Staebel Patient Transfer

The Staebel Patient Transfer Device is the perfect solution for safe transfer of a patient or resident within the home or facility. This is your all-in-one solution without the need for additional lifting straps and belts, and promoting independence. The width adjustable base allows good access to most seating, whilst also designed for good access beneath beds etc.

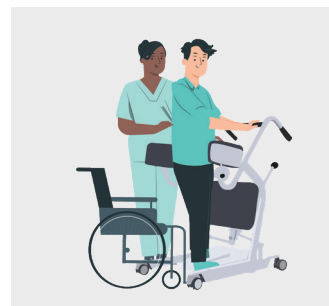

Specifications:

Product Code	212145
Seat Width	450 mm
Overall Width	640 mm
Overall Length	930 mm
SWL	150 kg



Return Transfer Platform

The ReTurn Transfer Platform, an assistance device for transferring clients, is specially designed to make different sit-to-stand and transfer situations easier for both clients and care givers. It is very easy to manoeuvre. It has been developed to facilitate work in confined spaces and it requires less effort than conventional lifting. In addition, instead of remaining passive, the patient is activated, which is a great advantage in comparison with lifting. Since the patient's own capacity is utilised and the device is easy to manoeuvre, the ReTurn is ideal for both home care and institutional settings.

The design of the ReTurn allows the client to get close to and to rise to standing position using natural movements. All of this adds up to a high degree of utilization. It is specially designed for short transfers in confined spaces. The knee supports are height adjustable which makes it easy to adapt the device for any patient. Many patients can use the Return from the same seat height.

The ReTurn's base plate is low and stable. With a increase in height of only 4cm, the patient does not need to lift his or her feet very high. Foot markers on the base plate simplify and ensure safe placement. ReTurn has two sections. This, together with its low weight, makes it ideal in a transport situation and the ReTurn is easy to keep clean and to store.



Specifications:

Product Code	217500i
Size	Adult
Base Width	685 mm
Base Length	570 mm
Height	1150 mm
SWL	150 kg

Also Available:

Product Code	217400
Size	Small
Base Width	685 mm
Base Length	570 mm
Height	995 mm
SWL	150 kg



Return Belt

ReTurnBelt is an excellent complement to ReTurn when more support and stability is needed, for instance when the user's weight-bearing ability is questionable or varied. ReTurnBelt can also be used stand alone for sit-to-stand, transfer and gait training procedures.

- Anti-slip inner surface
- PU-coated Nylon
- Range of sizes available



Specifications:

Product Code	216034M
Size	Medium
Width	1050 mm
Length	1250 mm
SWL	205 kg

Also Available:

Product Code	216033S	216035L	216036XL	216037XXL
Size	Small	Large	Extra Large	Extra Extra Large
Width	850 mm	1200 mm	1350 mm	1550 mm
Length	1050 mm	1450 mm	1550 mm	1750 mm



Camel Emergency Lifting Device

The Camel (Complete Air Moving Elevating Lift) is a state of the art air powered cushion designed to sit up and lift a fallen person from the floor.

Operating with low air pressure, the Camel offers an extremely stable and stress-free lift that can be performed either independently or with assistance from a carer.

With a maximum user weight of 320 kg, the Camel easily lifts people of any size and age but is particularly useful for lifting bariatric people, minimising the risks associated with moving and handling. Backrest provides extra support.

Elk Emergency Lifting Device

The ELK (Emergency Lifting Cushion) is an innovative air powered cushion designed to lift a fallen person from the floor.

Operating with low air pressure the Elk offers a stable and stress-free lift that can be performed with the assistance of one carer only. The product is extremely compact making it ideal when someone has fallen in a confined space both indoors and out.

With a maximum user weight of 450 kg, the Elk can lift people of any size, weight and age and is particularly useful for lifting very large and Bariatric people, minimising the risks associated with moving and handling for both the carer and client.



Specifications:

Product Code	2635
Max Height	560 mm
Min Height	Flat
Seat Depth	470 mm
Length	1120 mm
Width	700 mm
Weight	6.5 kg
SWL	320 kg



Specifications:

Product Code	2650
Max Height	560 mm
Min Height	Flat
Seat Depth	500 mm
Width	570 mm
Weight	3.6 kg
SWL	450 kg



Staebel Transfer Platform

Staebel Transfer Platform is a manually-operated device designed as a platform for use by healthcare professionals to assist in the physical moving (transfer) of a patient in an upright (standing) position over a short distance. The device consists of a wheeled platform, a surrounding framework, kneepad and handlebar. It can include safety belt, to hold the person being transferred in the standing position.

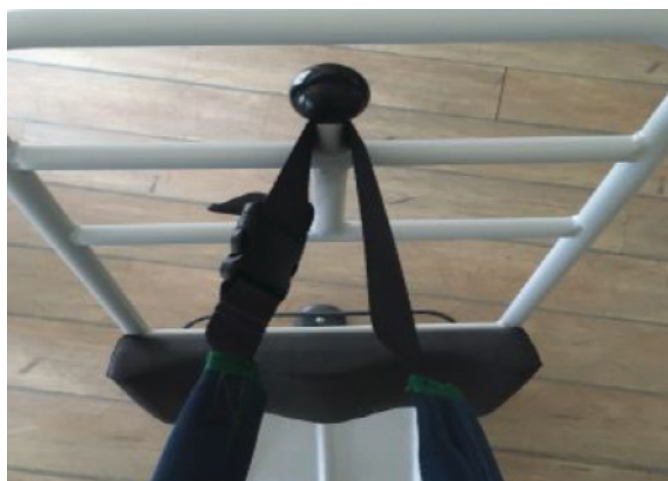

Specifications:

Product Code	212150
Width	620 mm
Height	1180 mm
SWL	150 kg



Staebel Belt

A supportive Belt to help with transferring or walking. The ergonomically designed handles enable the care giver to hold the patient close without the need to grab clothes. Ranging from Small to Large (adult sizes) this wonderful range of comfortable and supportive belts means that getting close to your patient has never been easier.

Simply place the belt around the person's waist, adjust to fit and then buckle. The ergonomically designed handles are perfectly located for user comfort and functionality. The belt is also washable.

- Helping a person from sitting to standing and vice versa
- Walking
- Supporting
- Helping whilst transferring on a sitting transfer board
- Comfortable to wear
- Give a feeling of added security
- Easily adjusted to fit

Specifications:

Product Code	210082	210083	210084
Size	Small	Medium	Large
Width	250 mm	250 mm	250 mm
Length	730 - 910 mm	850 - 1040 mm	1040 - 1170 mm

03.

Ceiling Hoists

SugarGlider Nomad Portable Ceiling Hoist	29
SugarGlider Monarch Portable Ceiling Hoist	30
SugarGlider Monarch Fixed Ceiling Hoist	30
SugarGlider Luna Portable Ceiling Hoist	31
SugarGlider Luna Fixed Ceiling Hoist	31
SugarGlider Transport Trolley	32
Flexi - Link Arm Reacher	32
Single Track Ceiling Hoist System	33
Case Studies	34

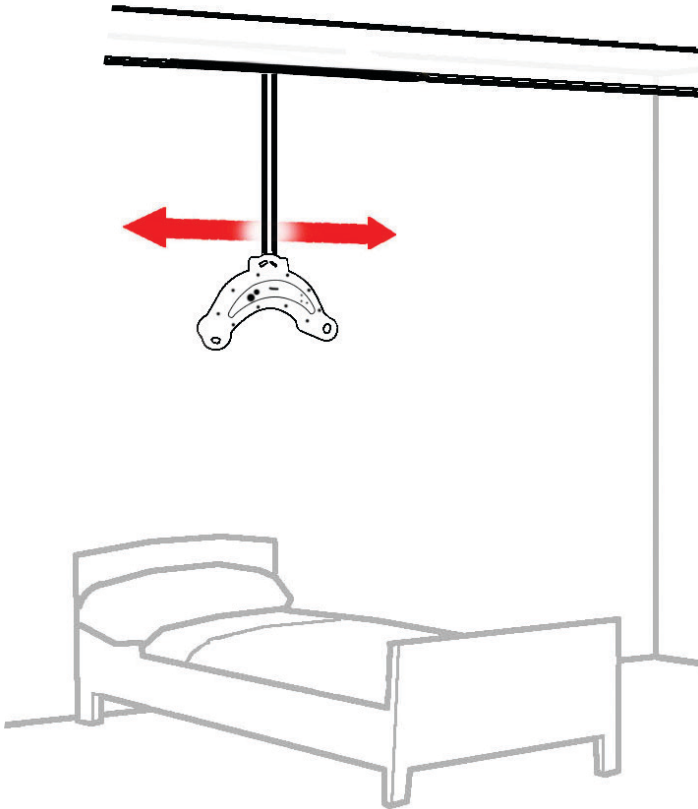

SugarGlider Nomad Portable Ceiling Hoist

The Nomad is a flexible and user friendly ceiling hoist. It is intuitive and easy to operate. The integrated handles make it truly portable. The curved shape is designed to afford user's head ample space while the integrated 4-point yoke gives ultimate safety, comfort and dignity during the lift and transfer. The user will feel safe and stable without being squeezed.

The combination with a compatible sling ensures that the user will achieve a correct and comfortable sitting position. If rail installations through door openings are not possible, the Nomad can climb from room to room, i.e. from one rail system to another. The Nomad has an emergency lowering and an emergency stop, as well as a soft stop-start function to prevent abrupt movements.

- Lift speed 35 mm/s with soft start/stop function
- High battery performance (70+ lifts per charge)
- Easy overnight charge system
- Built in electronic lift counter
- Splash proof casing
- Lifting Height 2m



Specifications:

Product Code	7324
Length	520 mm
Width	198 mm
Height	330 mm
Lift Range (Length of Lift Strap)	1980 mm
Lifter Weight	6.8 kg
SWL	230 kg

Also Available:

Product Code	7325
Length	520 mm
Width	198 mm
Height	330 mm
Lift Range (Length of Lift Strap)	1980 mm
Lifter Weight	6.8 kg
SWL	255 kg



SugarGlider Monarch Portable Ceiling Hoist

The Monarch Portable Ceiling Hoist is one of the lightest on the market weighing only 5kg, whilst lifting the industry standard of 200kg. Ideal for occasional or multiple room use, the product is robust and charges with an AC Charger.

- Weight: 5KG
- Lifts per Charge: 30 to 40 cycles
- Track Options: H system, Turntable, Gate, Curves, Room-to-Room, Freestanding Gantry: 2m, 3m, 4.5m, 6m, 8m
- Track Compatibility: Compatible with all Monarch tracks



SugarGlider Monarch Fixed Ceiling Hoist

The Monarch Fixed Ceiling Hoist is a complementary product to other products for individuals with mobility challenges. It is designed for use by caregivers and health professionals to lift and transfer a person in homecare, assisted-living or hospital environment.

- Unique Spreader Bar with Secure Sling Mechanism
- Fast - lifts up to 30% more quickly than other models
- Low lift clearance - slim profile means more room to manoeuvre patient
- Li-ion battery - recharges twice as fast as average competitor products
- Ultra lightweight - Weighing 8kg 35% lighter than competitors
- 200kg safe working load
- Ideal for Nursing Homes, Hospitals or Domestic Use



Specifications:

Product Code	272358000
Length	550 mm
Width	140 mm
Lifts per Charge	30 - 40 Cycles
Total Weight	4.8 kg
SWL	200 kg



Specifications:

Product Code	272358001
Length	640 mm
Width	300 mm
Lifts per Charge	30 - 40 Cycles
Total Weight	7.58 kg
SWL	200 kg



SugarGlider Luna Portable Ceiling Hoist

When combined with the E-track, the Luna powered ceiling hoist creates a versatile overhead lifting solution suitable for any room or lifting need.

The Luna overhead tracking hoist is unique in making a track hoist into a flexible technical aid. Luna can be mounted in different positions on the track and may be changed at will to suit varying care needs. The Luna track unit can also be adapted to suit existing tracks so that total replacement is not necessary.

- Soft start and stop motor control
- Electrical emergency lowering
- Electrical emergency stop
- Low battery indicator (visual LED)
- Charging indicators
- Power on indicators
- Overload protection
- Emergency brake system



Specifications:

Product Code	272333996
Length	320 mm
Width	130 mm
Length of Lifting Strap	2200 mm
Total Weight	6.7 kg
SWL	275 kg



SugarGlider Luna Fixed Ceiling Hoist

The Luna overhead tracking hoist is unique in making a track hoist into a flexible technical aid. Luna can be mounted in different positions on the track and may be changed at will to suit varying care needs.

The Luna track unit can also be adapted to suit existing tracks so that total replacement is not necessary. Luna can be described as a fixed and portable ceiling hoist in one and the same unit, a truly unique feature. Changing Luna from fixed to portable mode, and vice versa, can be done within seconds by simply detaching and reattaching the unit to the track. No tools are needed.

This unique two-in-one feature makes Luna the preferred ceiling hoist for care facilities as it provides a flexibility of choice, allowing the final decision of either fixed or portable unit to be made at a later point.

- Soft start and stop motor control
- Electrical emergency lowering
- Electrical emergency stop
- Low battery indicator (visual LED)
- Charging indicators
- Power on indicators
- Overload protection
- Emergency brake system



Specifications:

Product Code	272333997
Length	320 mm
Width	130 mm
Length of Lifting Strap	2200 mm
Total Weight	6.7 kg
SWL	200 kg



SugarGlider Transport Trolley

The SugarGlider Transport Trolley makes it a simple task to transport the portable ceiling hoist unit, reach stick and slings from one location to another.

- Two large shelves
- Features a unique column to store reach stick
- Four high quality swivel castors for ease of manoeuvrability
- Robust, heavy duty design favoured by many aged care facilities

Specifications:

Product Code	7426
Width	198 mm
Length	520 mm
Height	330 mm



Flexi-Link Arm Reacher

Efficient, safe and simple to operate. Our patented Flexi-Link connection system is today's most advanced device for connecting the portable lift to the trolley. Its removable wand allows carers to move around freely as there are no handles in place and travel of the hoist is not impeded by lights, fans or doors.

Specifications:

Product Code	7422FL
Length	600 mm

Also Available:

Product Code	7423FL
Length	900 mm

Single Track Ceiling Hoist System

When it comes to lifting a disabled person, a system that provides security, safety and comfort is required. Not just for those being lifted, but those doing the lifting. Part of our extensive product range focuses on patient handling aids for securely, safely and comfortably lifting and moving disabled people.

- Simple but comprehensive system, characterised by flexibility
- Ergonomically ideal alternative, eliminating manual lifting and allows caregiver to always choose the optimal working stance
- Requires minimum floor space and is easy to manoeuvre

- Provides the possibility of both low and very high lifting
- Complete, ingeniously simple and safe rail system for permanent installation on the ceiling and/ or on the walls
- Each system is individually designed in close cooperation with the customer allowing for adaption to specific conditions
- Optional choice of ceiling lift unit and the appropriate lifting accessories
- Unlimited possibilities for design and adaption of the perfect stationary lifting solutions for all settings, rooms and lifting needs.

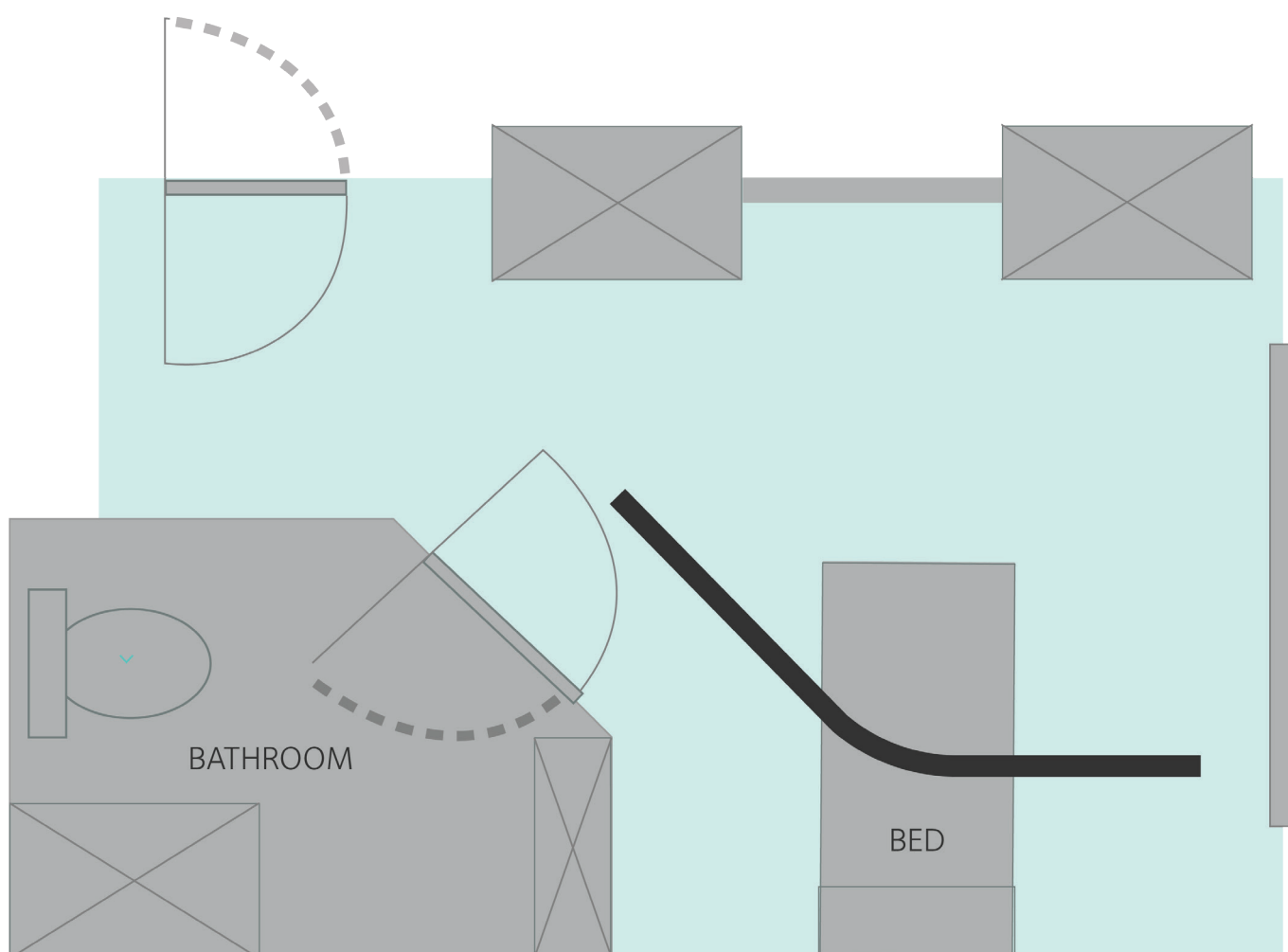

* Diagram shows Blue Care Standard Room for Ceiling Track System

Case Studies

Below are a few of the many different possibilities of design and adaption for the perfect lifting solution. These ceilings hoists have been installed in different settings and rooms such as bathrooms and bedrooms.



XY system (H System)



XY transition from bedroom to bathroom, shows door cutout.



Curved single track transitioned from XY



Straight track with power traverse motor



XY system to transition gate showing door cutout



Straight track with portable motor

04.

Pressure Care

MEDIUM RISK

Relax Easy Cushion	36
Action Gel Pilot Cushion	36
CuroCell SAM Mattress Overlay	37

HIGH RISK

Relax DuoGel Cushion	37
Optimal 5zon Mattress	38
CuroCell A4 Cirrus Air Mattress	38
Action Gel - Segment Pad (3 Per Bed)	39
Floor Impact Cushion High Visibility	39

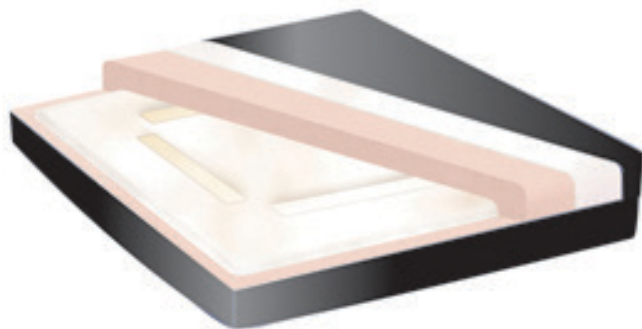

Relax Easy Cushion

This cushion from the Relax range is easy to use and is an ideal pressure relieving cushion for use in the nursing home environment. This combination of pressure relieving FloGel and viscoelastic foam facilitates effective pressure re-distribution while allowing the patient to immerse themselves comfortably into the cushion. The cushion has no specific front or back, top or bottom, making it simple to use.

- Conforms to shape of user, increasing surface area and relieving pressure
- Includes waterproof wipeable PU stretch outer cover
- Outer cover machine washable to 60° C
- Pressure Relieving FloGel – Segmented For Added Conformity

*Pressure Mapping Reports and successful Case Studies Available on request



Action Gel Pilot Cushion

The Pilot is a low-profile cushion that provides exceptional pressure relief for most users with a pressure ulcer history. 25mm of Akton polymer provides immersion for bony prominences and protects clients with fragile skin integrity. Incontinence covers are an optional extra

- Not restricted by a weight limit
- Easy to care for
- Quality, durable Pilot cover included – can be machine washed

*Custom sizes also available.



Specifications:

Product Code	35312
Width	450 mm
Length	400 mm
Thickness	50 mm
SWL	130 kg

Also Available:

Product Code	35100	35313	35315	353120
Width	400 mm	450 mm	500 mm	500 mm
Length	400 mm	450 mm	450 mm	500 mm
Thickness	50 mm	50 mm	50 mm	50 mm
SWL	130 kg	130 kg	130 kg	130 kg



Specifications:

Product Code	3531
Width	450 mm
Length	400 mm
Thickness	25 mm

Also Available:

Product Code	3530	3532	3533
Width	400 mm	450 mm	500 mm
Length	400 mm	450 mm	450 mm
Thickness	25 mm	25 mm	25 mm

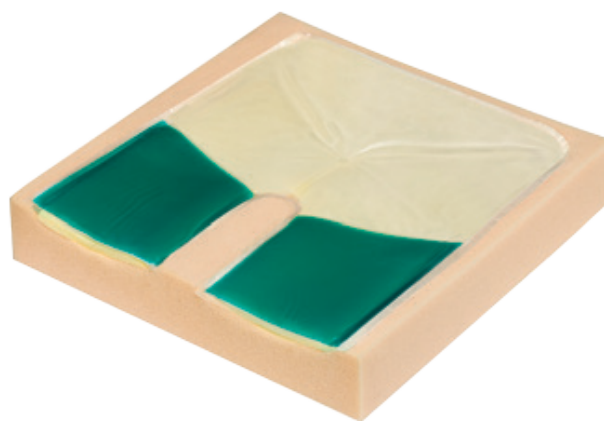

CuroCell SAM Mattress Overlay

The CuroCell SAM® is used as an aid in the prevention and treatment of pressure ulcers up to category 2, and for pain therapy. It is a static air mattress overlay system that provides very good comfort and pressure redistribution. The mattress is made from very soft and durable materials and comes with an easy to use, very quiet pump and CPR (rapid deflation of air). Thanks to the extra soft inner cover (accessory), the already low pressure is further reduced. Also available is the CuroCell SAM BAS, which is a mattress replacement system equipped with an integrated foam core, which is placed directly onto the bed frame.

This mattress is supplied with a four way stretch hygienic outer cover which conforms to relevant standards for hygiene, quality and safety. All covers are manufactured from modern, recyclable materials and are vapour permeable, which reduce the risk of skin maceration.

- Prevention and treatment up to and including category 2
- CPR function – rapid deflation
- Easy to handle and maintain
- Elastic fastening band
- Silent and energy-efficient pump
- Soft, elastic, vapour permeable hygienic cover
- Unique labeling
- Very good cleaning properties
- 2 year warranty
- Cleaning of cover: Wipe with cleaning agent and/or disinfectants. Machine wash max 95 °C, tumble drying.



Specifications:

Product Code	3670
Width	850 mm
Length	2000 mm
Thickness	100 mm
SWL	200 kg

Also Available:

Product Code	3671	3672	3673
Width	900 mm	1050 mm	1200 mm
Length	2000 mm	2000 mm	2000 mm

Relax DuoGel Cushion

The Relax DuoGel is a unique combination of TruGel and FloGel working together effectively to provide excellent pressure relief and weight distribution. The DuoGel's anatomical pre-contoured base provides for medial and lateral thigh positioning as well as support for the greater trochanter of the thigh bone. The thigh troughs are lined with TruGel and the ischial area is lined with FloGel which is set on a viscoelastic foam giving greater comfort and seating stability.

- Thigh troughs assist with seating stability
- Fast Recovery Foam (Anatomically Shaped)
- Includes machine washable outer cover (not pictured)
- Clear protective PU film coating – easy to clean and suitable for incontinent users
- Anatomical Pre-Contoured Foam Base



Specifications:

Product Code	35302
Width	450 mm
Length	400 mm
Thickness	80 mm
SWL	130 kg

Also Available:

Product Code	35300	35306	35303	35304	35307	35309
Width	400 mm	400 mm	450 mm	500 mm	500 mm	600 mm
Length	400 mm	450 mm	450 mm	450 mm	500 mm	450 mm
Thickness	80 mm	80 mm	80 mm	80 mm	80 mm	80 mm
SWL	130 kg	130 kg	130 kg	130 kg	130 kg	130 kg



Optimal 5zon Mattress

The Optimal 5zon® is ideal for all healthcare environments and is used as an aid in the prevention and treatment of pressure ulcers up to and including category 2, and for pain therapy. It is a soft and flexible mattress replacement that is placed directly on the bed and replaces both the standard mattress and mattress pad.

- Highly elastic, high-quality material and a unique zone and module system gives effective pressure equalisation.
- Specially designed to minimise shear forces
- Simple and effective cleaning, cover has a very well documented hygiene standard
- The hygienic cover is vapour permeable, which reduces the risk of skin maceration
- The patented sit function DuoCore® is designed to give support when sitting and also to provide good comfort when lying
- Heel Protection provides comfort for relief of heel. The user can move the leg and make position changes. Comes with a removable liquid resistant hygiene cover.



CuroCell® A4 Cirrus Mattress

CuroCell® A4 Cirrus is used as an aid in the prevention and treatment of pressure ulcers up to and including category 4 and unclassified pressure ulcers/pressure injuries⁽¹⁾. It is a replacement system suitable for all healthcare environments.

CuroCell® A4 Cirrus combines air with a soft foam surface and provides good user comfort and pressure redistribution⁽²⁾. The added heel function offers pressure redistribution on the heels.

- Automatic control unit which adapts individual to the user
- User friendly interface
- Audible and visual notifications
- Three program modes: pulsating mode, alternating mode and constant low pressure
- Silent running and vibration free
- Air flow control; Constant temperature, good user comfort, energy reduction
- Soft foam surface
- Smart cable management
- Easy handling and cleaning
- Heel slope, for pressure redistribution of heels
- CPR-function with transport function



Specifications:

Product Code	3771
Width	850 mm
Length	2000 mm
Thickness	140 mm
SWL	180 kg

Also Available:

Product Code	3778	3775
Width	1000 mm	1050 mm
Length	2000 mm	2000 mm
SWL	180 kg	180 kg

Specifications:

Product Code	3674A4
Width	850 mm
Length	2000 mm
Thickness	210 mm
SWL	230 kg

Also Available:

Product Code	3840
Width	800 mm
Length	2000 mm
SWL	230 kg



Action Gel - Segment Pad (3 Per Bed)

The Action bed overlays (pictured) are made of Akton polymer which mimics human fatty tissue in consistency, does not migrate like gel and provides equally distributed pressure management, with varying sizes available, these overlays can be used to cover the entire surface or isolated areas of an existing standard mattress. Patients can use one, two or three segments in combination on their areas of need e.g. shoulders and hips, feet and hips or full body etc.

- Easily cleaned, no maintenance
- Not restricted by any weight limit
- 3 Segments cover length of single bed. Each sold separately

Floor Impact Cushion High Visibility

- Helps reduce impact forces by up to 85%
- Low profile edge and high visibility glow strip reduces the risk of tripping
- Tested according to ASTM test protocol for shock absorbency
- EVA Foam with bevelled edge on three sides
- Wipe clean vinyl cover
- Non-Skid bottom
- Tri-fold design with convenient carrying handle
- Generous size helps provide full coverage of the bed exit area
- Quality product made in USA



Specifications:

Product Code	3853
Width	630 mm
Length	690 mm
Thickness	18 mm
SWL	Unlimited

Specifications:

Product Code	9PP58234
Width	970 mm
Length	1780 mm

05.

Wheelchairs

Staebel Liberation Lightweight Wheelchair	41	Sovereign Transit Wheel Kit	44
Staebel Emperor Wheelchair	41	Sovereign Head Support	44
Staebel Transit Emperor Wheelchair	42	Sovereign Arm Trough One Piece	45
Relax Tilt & Recline Wheelchair	42	Sovereign Seat Belt	45
Sovereign Wheelchair	43	Sovereign Drum Brake Kit	45
Sovereign Armrest Pad	44	Sovereign Stump Support	45
Sovereign Anti-Tip Bars	44	Sovereign Elevating Legrest	45
Sovereign Power Assist	44	Sovereign Pelvic Strap	45
Sovereign One Arm Drive Kit	44		



Staebel Liberation Lightweight Wheelchair

The Staebel Liberation Lightweight Wheelchair is a great travel companion. It is a sleek modern design that has been kept compact for easy transport and storage.

- Fully foldable backrest
- Dual brake
- Parking brake push handle
- Fold-up armrests
- Lightweight foldable swing-way footrests



Specifications:

Product Code	40400
Seat Width	450 mm
Overall Width	540 mm
Overall Height	920 mm
Product Weight	7 kg
SWL	100 kg



Staebel Emperor Wheelchair

The Staebel Emperor is a comfortable, lightweight aluminium wheelchair, with a really helpful range of high quality features. With its sleek modern frame and lightweight foldable design, the wheelchair is perfect for travel. All features of this chair have been designed to make life easier for the user.

- Foldable backrest
- Lap belt
- Heel strap
- Height adjustable armrests and footplates
- Removable swing-away footrest
- Available in Blue or Orange



Specifications:

Product Code	40411
Seat Width	450 mm
Overall Width	670 mm
Overall Height	950 mm
Product Weight	12 kg
SWL	115 kg

Also Available:

Product Code	40412
Seat Width	500 mm
Overall Width	720 mm
Overall Height	950 mm
Product Weight	15 kg
SWL	135 kg



Staebel Transit Emperor Wheelchair

The Staebel Emperor is a comfortable, lightweight aluminium wheelchair, with a really helpful range of high quality features. With its sleek modern frame and lightweight foldable design, the wheelchair is perfect for travel. All features of this chair have been designed to make life easier for the user.

- Foldable backrest
- Lap belt
- Heel strap
- Height adjustable armrests and footplates
- Removable swing-away footrest
- Available in orange or blue.



Specifications:

Product Code	40413
Seat Width	450 mm
Overall Width	670 mm
Overall Height	950 mm
Product Weight	12 kg
SWL	115 kg

Also Available:

Product Code	40414
Seat Width	500 mm
Overall Width	720 mm
Overall Height	950 mm
Product Weight	15 kg
SWL	135 kg



Relax Tilt & Recline Wheelchair

The Relax Tilt and Recline is the latest in modular design. This quality aluminium wheelchair has a gas assisted tilt and recline adjustment built into the one product. The many adjustments within the chair features means it can be adapted to the individuals needs, removing the need to opt for a custom made product in many cases.

- Gas assisted seat tilt and recline
- Contoured adjustable headrest
- Height adjustable comfort backrest with lateral support
- Depth adjustable comfort seat with pommel
- Multiple axle positions provide adjustable seat height and wheelbase length
- Quick release rear wheels
- Adjustable height armrests with padded side guards
- Wingaway removable elevating legrests with calf pads and angle adjustable footplates
- Adjustable height push handles
- Anti tip wheels
- *Also available in 51cm seat width



Specifications:

Product Code	4631
Seat Width	460 mm
Seat Depth	380 - 500 mm
Seat Height	410 - 520 mm
Backrest Height	500 - 650 mm
SWL	140 kg

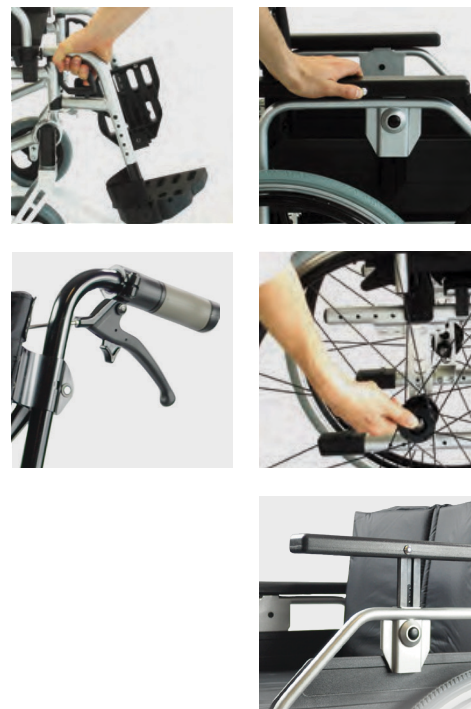

Sovereign Wheelchair

The Sovereign wheelchair can be adjusted to suit almost any user. With much consideration in the design from the perspective of OTs, this chair is suited to the vast range of needs required by our clients.

Rather than numerous script forms for various users, this chair meets the needs of almost any patient. All wheelchair parts suit any adjustments made - no additional parts required!

- Adjustable & removable legrests
- Flip back & removable armrests
- Adjustable armrest height & length
- Seat depth, height & angle adjustment
- Backrest height, tension & angle adjustment



Specifications:

Product Code	4340C-43	4340C-46	4340C-49	4352C-52	4352C-55	4352C-58
Seat Width	430 mm	460 mm	490 mm	520 mm	550 mm	580 mm
Anterior Seat Height	420 mm	445 mm	450 mm	470 mm	475 mm	500 mm
Posterior Seat Height	410 mm	430 mm	450 mm	470 mm	490 mm	510 mm
Seat Depth	400 mm	425 mm	450 mm	475 mm	475 mm	500 mm
Backrest Height (2cm increments)	400 - 460 mm	400 - 460 mm	400 - 460 mm	400 - 460 mm	400 - 460 mm	400 - 460 mm
Backrest Angle (5° increments)	69° - 94°	69° - 94°	69° - 94°	69° - 94°	69° - 94°	69° - 94°
Lower Leg Length (2cm increments)	400 - 480 mm	400 - 480 mm	400 - 480 mm	400 - 480 mm	400 - 480 mm	400 - 480 mm
Armrest Height (2cm increments)	180 - 260 mm	180 - 260 mm	180 - 260 mm	180 - 260 mm	180 - 260 mm	180 - 260 mm
Armrest Length (4cm increments)	330 - 450 mm	330 - 450 mm	330 - 450 mm	330 - 450 mm	330 - 450 mm	330 - 450 mm
Footplate Width	105 - 155 mm	105 - 155 mm	105 - 155 mm	105 - 155 mm	105 - 155 mm	105 - 155 mm
Gross Weight	17 kg	17 kg	17 kg	21 kg	21 kg	205 kg
SWL	125 kg	125 kg	125 kg	170 kg	170 kg	205 kg



Sovereign Armrest Pad

Wheelchair Parts - Armrest pad, to suit sovereign wheelchair.

- Left or right side configured - specify when ordering

Specifications:

Product Code	43446 - L
Product Code	43446 - R



Sovereign Wheelchair - Anti-Tip Bars

Wheelchair Accessory - Anti-tip bars, to suit Sovereign Wheelchair.

Specifications:

Product Code	43411
--------------	-------



Sovereign Power Assist

- Only suitable for Sovereign Wheelchair
- Aluminium frame with PU grey wheels.
- Includes controller, battery and charger.
- Two sizes available: 180W (43428) and 320W (43429).

Specifications:

Product Code	43428
--------------	-------



Sovereign One Arm Drive Kit

One arm drive system with double push rim (Must specify left or right at time of order)

Specifications:

Product Code	43425
--------------	-------



Sovereign Transit Wheel Kit

Transit wheel kit, to suit Sovereign Wheelchair
Not compatible with 52, 55, 58 cm

Specifications:

Product Code	43426
--------------	-------



Sovereign Head Support

- Head Support to suit Sovereign Wheelchair
- Height Adjustable

Specifications:

Product Code	49608
--------------	-------



Sovereign Arm Trough One Piece

The arm trough is of benefit for the wheelchair/shower chair user who has upper limb weakness or paralysis. It attaches to the chair armrest via a clamp.

- One piece moulded polyurethane trough
- Supplied with hardware
- Can be mounted left or right side

Specifications:

Product Code 4985



Sovereign Seat Belt

This seat belt is a simple device for safety and positioning. It has a push button buckle and is adjustable in length. It has metal eyelets to enable attachment via existing seat upholstery screws on the wheelchair.

- Adjustable in length
- Simply and easily fitted to most wheelchairs

Specifications:

Product Code 4974



Sovereign Drum Brake Kit

- Drum Brake Conversion Kit for the Sovereign Wheelchair
- Includes Brakes, Cables & Wheels

Specifications:

Product Code 43410



Sovereign Stump Support

The stump support is used on a wheelchair in place of the regular legrest, and is useful for amputees with a below knee amputation.

- Adjustable pad height
- Left or right side configured – specify when ordering

Specifications:

Product Code 43417 - L

Product Code 43417 - R



Sovereign Elevating Legrest

This seat belt is a simple device for safety and positioning of the wheel chair user. It features a push button buckle and has metal eyelets to enable attachment via existing seat upholstery screws on the wheelchair.

- Adjustable in length
- Left or right side configured – specify when ordering

Specifications:

Product Code 43416 - L

Product Code 43416 - R



Sovereign Pelvic Strap

- Plastic side release buckle belt, 2-piece design
- Loop tie attachment around wheelchair/shower chair frame
- Length adjustable 80-155 cm

Specifications:

Product Code 19636



06.

Seating

Regency Care Chair	47
Embark Deluxe Day Chair	48
Utilite Day Chair	48



Regency Care Chair

The Regency Care Chair is designed to give the patient comfort by combining the original tilt system with an independent multi-positional back rest. Its many features take into account the needs of both carer and user of the chair. The Regency R2900 derives its status from a proven and successful track record across a broad spectrum of the industry.

- Reclining backrest – full recline to supine position
- Tilting seat
- Pressure management seating – gel cushion in seat, self-air adjusting back, profiled head cushion
- 2-position armrests
- Forward seat tilt for ease to stand, legrest angles under seat
- Elevating contoured legrest complete with fold out, extendible footplate
- Low skin shear 2-way stretch fabric on seating surfaces
- Drop down armrests and swingaway headwings – side transfer friendly
- Covers replaceable
- Patient lifter friendly castor base
- 5 year limited warranty
- 175mm castors, braking on rear, directional lock on front
- Quality Australian made construction
- Available in different colours and styles

Colours available:



Specifications:

Product Code	5050G
Seat Width	460 mm
Seat Depth	520 mm
Seat Height	600 mm
Backrest Length	700 mm
Armrest Height	175 mm

Legrest Length	480 - 650 mm
Overall Width	660 mm
Overall Depth	1040 mm
Overall Height	1310 mm
SWL	180 kg



Embank Deluxe Day Chair

An exceptional rehabilitation chair, the Embark Deluxe is available in sturdy quality vinyls for ease of cleaning. The adjustable seat height, seat depth and angle ensures Embark Deluxe can adapt to the widest range of people, making this chair ideal for hospital, home and nursing home. The padded seat and back rest have been designed to enhance the posture, whilst providing maximum comfort.

- High backrest incorporating lumbar and lateral support
- Padded armrests
- Comfortable vinyl upholstered seat and back
- Adjustable seat height and depth
- Powdercoated steel frame
- Standard with tilt and move wheels for ease of manoeuvrability
- Different colours available. Contact the team for more information



Specifications:

Product Code	5930
Seat Width	500 mm
Seat Depth	450 - 530 mm
Seat Height	450 - 600 mm
Backrest Height	790 mm
Arm Height	230 mm
Overall Width	700 mm
Overall Depth	730 - 800 mm
Overall Height	1200 - 1350 mm
SWL	200 kg

Also Available:

Embank Day Chair Legrest	
Product Code	5958



Utilite Day Chair

The Utilite is a multi purpose adjustable seat height and angle chair. Ideal for use in an area where adjustable seating is required, for example, lounge, dining room, bedroom, activity room, outdoor area etc. This low back chair provides comfort, stability and practicality at an affordable price.

- Shallow curved low backrest
- Padded armrests
- Comfortable, durable upholstered seat, back and armrests
- Powdercoated steel frame
- Different colours available. Contact the team for more information



Specifications:

Product Code	5910
Seat Width	460 mm
Seat Depth	460 mm
Seat Height	485 - 640 mm
Backrest Height	455 mm
Arm Height	230 mm
Overall Width	610 mm
Overall Depth	550 mm
Overall Height	900 - 1075 mm
SWL	120 kg

07.

Mobility Solutions

Petite Seat Walker	50
Stimulator Rehab Forearm Support Walker	50
Traymobile Tray Walker	51



Petite Seat Walker

- Ideal for smaller people requiring mobility assistance
- Durable lightweight aluminium frame
- Folding for convenient transport and storage
- Height adjustable handles
- Ergonomically designed rubber hand grips
- Fitted with rear braking and front swivel castors
- Locking brake mechanism with reflectors
- Padded seat
- Supplied with reinforced vinyl bag
- Removable backrest



Specifications:

Product Code	6771
Seat Width	300 mm
Seat Depth	300 mm
Seat Height	550 mm
Overall Width	570 mm
Overall Depth	670 mm
Overall Folded (WxDxH)	570 x 350 x 815 mm
Handle Height	815 - 925 mm
Castor Size	194 x 40 mm
Walker Weight	7.4 kg
SWL	200 kg



Stimulator Rehab Forearm Support Walker

The best rehab program and the best rollator will guarantee you the best results – is this what you're looking for? Our Stimulator Rehab Forearm Walker has been specifically designed for the needs of the Aged care and Acute Care/Hospital environment.

- Very lightweight, easy for the frail, weak patient to use
- High quality castors with super smooth rolling and minimal friction even on carpet, taking away any shuddering or wobbling
- Easy, simple and very gentle lever height adjustment
- Soft PU multi adjustable arm pads for any patient with any specific position requirement
- Multi adjustable hand grips, for the arthritic, ABI or stroke patients.
- Overall width designed to fit through nearly any doorway
- Four swivelling castors for ultimate manoeuvrability
- Individual brakes on each castor, as well as hand brakes
- Modern streamlined design gives an up-to-date image to your rehab and physio area



Specifications:

Product Code	6755
Overall Width	700 mm
Height of Arm Supports	905 - 1310 mm
Width Between Arms	310 - 470 mm
Overall Length	810 mm
SWL	200 kg



Traymobile Tray Walker

This walker is ideal for the person requiring extra support when indoors, giving the user greater independence. The four swivel castors makes it excellent for manoeuvring in small spaces. Two removable trays are fitted to this walker to allow small items to be transported by the user and can also act as a table. The adjustable height legs allows the walker to be fitted to the individual users height requirements. Also available with two front wheels and rear gliders.

- Height adjustable to suit the client's needs
- Lightweight aluminium construction
- Two removable trays to assist transporting smaller items
- Supplied with four small castors for indoor use



Specifications:

Product Code	6650
Height	800 - 950 mm
SWL	200 kg

Hey There!



Want to see more?

Reach out today to see more of our mobility solutions!

P: 1800 267 267

W: www.activemedicalsupplies.com.au

E: hello@activemedicalsupplies.com.au

08.

Bedroom Solutions

Sentida 6 Bed	53
Nino Adolescent Bed	54
Tom 2 Cot	55





Sentida 6 Bed

Known for its ambient non-institutional appearance the Sentida's features include:

- Compliance with standard IEC 60601-2-52
- Unique Multi-position Mobilisation Aid which have 4 positions and very useful for effective mobilisation as they are easy to grab and clasp. They can be used as a safe standing-up aid and verifiably support the resident's mobility. Easy to adjust and are hidden behind a side board when lowered.
- Great movability with 100mm easy-roll castors at both bed ends
- Foot-end bar brake with 4 castor central braking system
- Minimal gap between edge of mattress surface and side guard
- Double retracting sleeping surface to reduce friction & shearing forces. Also will aid in relief of pressure in sacral area
- Underbed clearance for patient lifters at any position
- Unique comfort seating position to make patient breathing easier, as well as digestion
- Vertical raise therefore no risk of holes in walls behind the bed
- Handset lockout function so care staff have control in dementia care setting
- Unique hand control with 2 button operation reducing risk of accidental bed adjustment
- TGA approved
- 36 month warranty
- Quality German made construction
- Customisable styles available
- Also available in King Single and LE version



Specifications:

External Dimensions	2080 x 1060 mm
Sleeping Surface	2000 x 870 mm
Bed Extensions	200 mm
Max Sleeping Surface Height	800 mm
Min Sleeping Surface Height	270 mm
SWL	270 kg

Also Available:

Sentida 6 Bed, Low Height, King Single

Product Code	77713C
SWL	270 kg

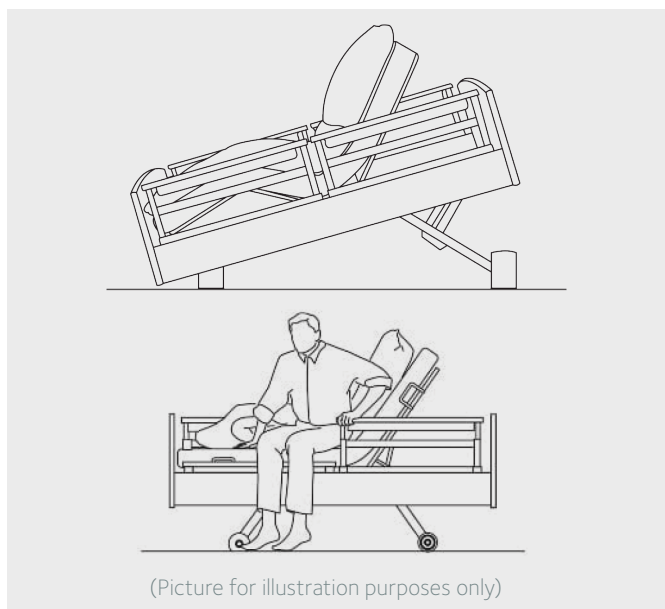



Nino Adolescent Bed

The Nino Series allows children to perceive the world around them while at the same time providing protection and security. The transparent Perspex merges with the room allowing occupants to have an unrestricted view of their immediate surroundings yet still protects against falls and injuries. Also available in different powdercoat colours, or with higher door elements or doors on both sides.

- Nino Series – Single Width
- Electric Hi-low
- Electric Backrest
- Electric Kneebreak
- Standard Locking Castors
- Gates one side with Perspex infills
- Fixed Panel one side with Perspex Infills
- 750mm High Sides (from Mattress Base)
- Head & Foot Infills in Natural Oak Matt Finish
- Battery Backup



Specifications:

Overall Dimensions	2200 x 1014 mm
Sleeping Surface Dimensions	2000 x 870 mm
NET Bed Weight	140 kg
Underbed Clearance	100 mm (at lowest point)
Low Position	390 mm
High Position	830 mm
SWL	200 kg

Configuration Possibilities:





Tom 2 Cot

A state-of-the-art children's cot must be safe and be able to provide excellent access for nursing staff. The electric positioning of TOM 2 children's cot responds to these and further demands in its original concept of telescopic siderails, column construction mechanism and above standard safety parameters.

The Tom 2 bed fully complies with the new standard for hospital children's beds. DIN 32623:2009-11 and its construction guarantees perfect protection against children fall. Also complies with standards: EN 60601-1, EMC 60601-1-2, EMC 60601-1-6

- 3 height positions for side rails, 0cm, 40cm, 80cm
- Backrest retracts when it raises, meaning zero gap
- Integrated collapsible lockable side rails
- 4 x Tente Motion 125mm castors
- Central operated castors (one castor with steer system)

- 4 x holders for IV in corners of bed
- Undercarriage cover
- Removable head/foot ends
- Accessory holders: Pair of accessory rails (located on both sides under side rails)
- Battery Backup
- Horizontal Wall/corner bumpers
- Pastal Blue Trim with Teddy Decor
- Quality European product



Specifications:

Product Code	76765
Mattress Platform	1400 x 700 mm
Electric Hi-Lo	580 – 830 mm
Electric Tilt/Reverse Tilt	15°
Backrest Adjustment	40°
SWL	75 kg

Also Available:

Tom 2 Cot Mattress

Product Code	76751
---------------------	-------





activeMEDICAL
SUPPLIES > SOLUTIONS > SUPPORT

P. 1800 267 267 | F. 07 3899 8825
E. hello@activemedicalsupplies.com.au

www.activemedicalsupplies.com.au